

**BID REFERENCE DOCUMENTS**

**HOPKINS CANAL PIPING PROJECT**

**ROGUE RIVER VALLEY IRRIGATION DISTRICT**

# Section View

# Plan View

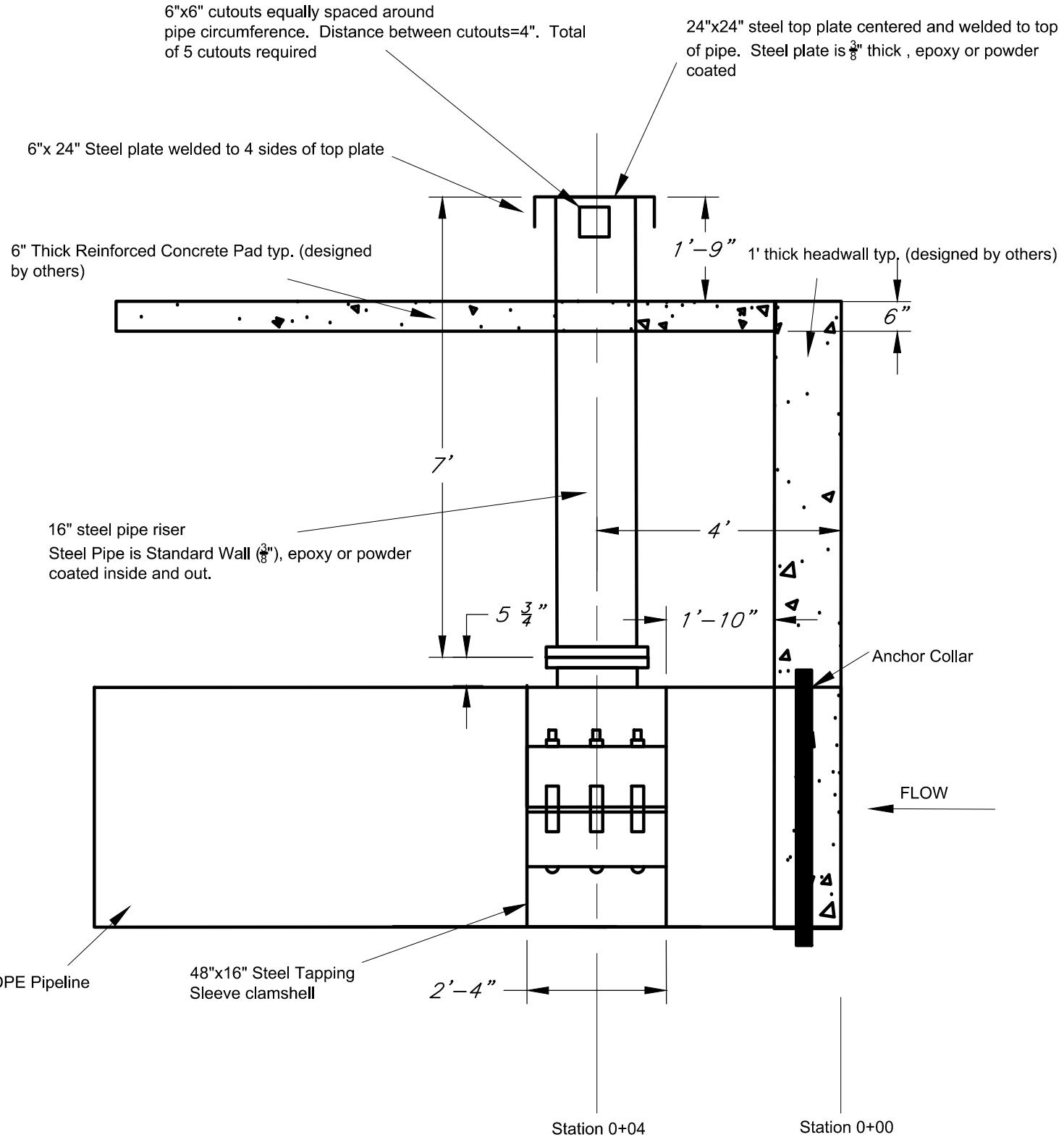
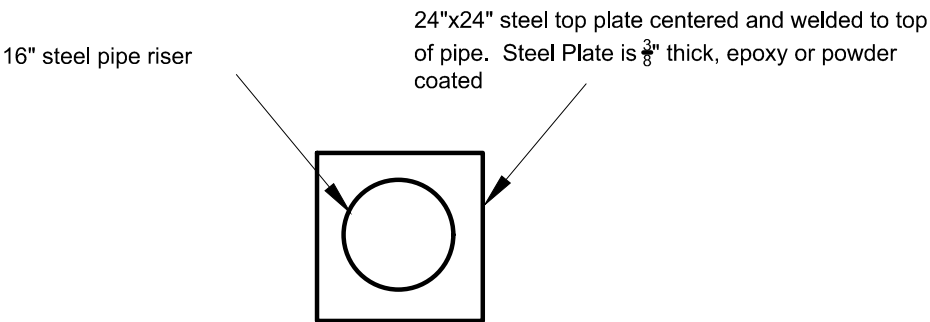

**STAND PIPE AIR VENT DETAIL**

Date	
Designed_PD & WC	
Drawn_PD & WC	
Checked_W.C.	
Approved	
Title	

**Stand Pipe AirVent Detail**

**HOPKINS CANAL PIPING PROJECT – PHASE 2**

JOB CLASS: VI

PRACTICE STANDARD(S): 430, 587

BASIN: SOUTHWEST

JACKSON COUNTY, OREGON



File Name	RRV02_1-9_MASTER_18-07-11.dwg
Drawing No.	
7/9/2018 4:04 PM	
Sheet 9 of 36	